



User Manual

Strongbond Grinder Model: FNX800

Flooring Wholesale Limited

T/A Look Floors

9 Industry Road,

Penrose, Auckland 1061,

New Zealand



Introduction

Thank you for using Strongbond floor grinder Model FNX800 distributed by Flooring Wholesale Limited T/A Look Floors. This model FNX800 is a multi-functional floor grinder. It is used for grinding and polishing of old and new floor, which greatly improves the efficiency of construction, renovation and maintenance of concrete, Stone, and epoxy floor. It meets the high standards of surface treatment and maintenance, saves construction time and cost, the operation of machine is easy and efficient.

This manual provides as detailed a description as possible of the use, maintenance, attention and caution, fault diagnosis and countermeasures of the grinder FNX800 provided by STRONGBOND. This manual is a guide to your proper use, realizing its superior performance and safe operation. Please ensure to read it in detail and keep it in a safe place. In the use process, if there are any difficult problems or special requirements, please contact LOOK FLOORS, we will serve you wholeheartedly.

Our company has always been committed to continuous innovation and improvement of equipment, If the product of this model has been improved and its relevant information has been changed, we will update it as soon as possible.



Contents

Chapter I Safety and Attention

- 1.1 Safety guidance
- 1.2 Precautions

Chapter II Inspection, Technical Data and Product Description

- 2.1 Inspection
- 2.2 Technical Data
- 2.3 Product Description

Chapter III Operational Instructions

- 3.1 Method of operation
- 3.2 Equipment relocation after use
- 3.3 Handling of equipment

Chapter IV Equipment Connections and Reset of Inverter

- 4.1 Guide to wiring
- 4.2 Switch boxes, inverter and electrical wiring
- 4.3 Reset of inverter

Chapter V Maintenance and Repair of Equipment

- 5.1 Maintenance and repair

Chapter VI Quality Assurance

- 6.1 Scope and duration of warranty
- 6.2 Conditions of warranty

Chapter VII Simple Fault Removal



Chapter I Safety and Attention

To ensure the safety of your machine operator, equipment and property, please read this manual carefully before using the machine. Strictly follow and implement the manual in the process of handling, installation, debugging, operation and overhaul.

1.1 Safety guidance

- (1) Operators must wear waterproof and insulated work safety shoes and gloves, it is strictly prohibited to operate the machine barefoot.
- (2) The power supply cable shall use insulated soft cables produced by the regular manufacturer that meet the relevant national standards. The cable shall use a cross-sectional area of $3 * 4 \text{ mm}^2 + 1 * 2.5 \text{ mm}^2$ or more, that is, the cross-sectional section (Square mm) of the three live wires shall be 4 mm^2 or more, the cross-sectional area of a grounding line must be 2.5 mm^2 , and the grounding line must be firmly grounded to prevent leakage.
- (3) Before using the machine, it is necessary to carefully check whether the power cord is broken or worn. If this occurs, the power cord should be replaced immediately to prevent short-circuit leakage.
- (4) Before the machine is plugged in, you must carefully check whether the electrical control box has a leakage protection device, whether it is firmly grounded, and whether the socket is grounded.
- (5) It is strictly prohibited for personnel to sit on the motor of the machine; Do not place machine and cable plugs in water or in overly humid environments or use high-pressure water to shower motors and electric boxes to avoid short-circuits and damage to equipment and injury to personnel.
- (6) During wet grinding, the motor, inverter, and control panel shall be waterproof protected to avoid short-circuit or leakage of electricity from the equipment line, resulting in the inability of the machine to operate.
- (7) When using the machine, do not crush the wire. Avoid causing damage to the wire and causing safety hazards.
- (8) When using the machine, please do not plug in by wet hands so as not to cause injuries.
- (9) In the process of moving the machine, please use the appropriate handling tools and methods to avoid causing the equipment to fall, roll and crash causing injuries.



1.2 Precautions

- (1) After both dry or wet grinding, clean the dust or mud at the bottom of the gearbox. Also clean the bottom of the gearbox when the abrasive is changed, to improve the heat dissipation effect of the gearbox and increase the service life of the machine.
- (2) When dry grinding, please connect to the vacuum cleaner to reduce dust pollution to the inverter and ensure normal operation of the machine. The operator should wear dust protection and other necessary safety equipment.
- (3) In the process of replacing consumables and handling machine, please ensure that the machine is lightly placed. In particular, it is prohibited to move the handle lock to avoid the impact of the gearbox causing oil leakage and injury to others (if one person cannot easily carry the machine during the operation, please find someone to help). The additional weight must be moved backwards to ensure that the center of gravity of the machine is backward.
- (4) The inverter may produce resonance within a certain output frequency range and cause the device to stop working. In this case, please avoid resonance frequency operation.
- (5) When working on the floor with a large fall, be sure to grind from the high point to the low point to avoid damaging the grinding discs and gearbox (grind in a downwards direction).
- (6) Often check the grinding discs, if the grinding disc is loose and the bolt is bent, please maintain and change the bolt in time.
- (7) Please note whether there is a steel bar protruding or serious groove on the ground before or during grinding, if so, please handle it in time, and keep away from it to prevent the machine gearbox from being damaged due to impact.
- (8) Additional weight is the sliding design, please lock after sliding.

Chapter II Inspection, Technical Data and Product Description

2.1 Inspection

- (1) Before unpacking, please check whether the outer packaging of the product has been damaged by careless transportation.
- (2) After opening the box, please check that the specifications and models of the products are in conformity with the order.



(3) Check the interior of machine for any damage. If there is any obvious damage, please do not operate or use the machine and contact LOOK FLOORS in time to avoid any accidents.

(4) Check the items are complete: one machine, two lifting rods, one water retaining belt, one industrial plug, one vacuum cleaner connector, and twelve abrasive switch discs.

2.2 Technical Data

Model	FNX800
Motor Power	11KW
Inverter Capacity	11KW (15HP)
Voltage	380V AC
Current	21.9A
Frequency	50Hz
Motor Speed	0~1800pm
Grinding Width	800mm
Grinding Disc	270mmx3
Quantity of Grinding Pads	12pcs * 100mm(4")
Weight	400Kg
Packing Size	1250*800*1050

2.3 Product Description



① -Handle ② -Hand shank ③ -Button ④ -Digital Panel ⑤ - Additional Weight ⑥ -Ventilation

⑦ -Electric Box ⑧ -Water tank ⑨ -Pedals ⑩ -Support Wheel ⑪ -Water Valve ⑫ -Motor ⑬ -Rubber

Wheel ⑭ -Frame ⑮ -Gear Box Cover ⑯ -shroud

Chapter III Operational Instructions

3.1 Method of Operation

3.1.1 Preparation for machine operation

- (1) First check whether the power switch is turned off to ensure safety.
- (2) Move the additional weight backward to the operator, hold the handle in both hands, step on pedal, press down hard, uplift the machine head and secure it. Check whether the gearbox output shaft connection disc, coupler and grinding discs are fully equipped, whether there is misloading, lack of parts or loose. If any parts are found out of place, please adjust immediately.



(3) After the inspection is complete, install the grinder on the grinder installation plate. The basic steps are as follows:

- (a) Clean the surface of the abrasive mounting surface, pin and magnet.
 - (b) Align the holes of the diamond abrasive matrix or the holes of the resin abrasive joint plate with the pins, insert them and be absorbed by magnets on the chassis, check for firmness, and note that the particle size of all abrasive tools in a set of processes must be the same.
 - (c) When fitted, hold the handle in both hands and put one foot on the pedaling pole. Using the body weight to balance the weight of the head, slowly lift the handle and gently put the head back on the ground. Take care not to hit the ground. Damage to gearbox, causing oil leakage, etc.. If one person is unable to operate easily during the operation, please find someone to help complete this operation.
 - (d) Turn the handle backwards and pull the handle pin to adjust the height of the handle to fit the position of the machine that is easy to operate.
- (4) Adjustment of handle
- (5) Before wet grinding, please inject the tank into the appropriate amount of water.

3.1.2 Machine Operation

- (1) Press the stop button, plug in the power, move the light on the digital panel to the voltage position, and check if the voltage is normal.
- (2) Turn the speed knob back to the **minimum speed**, release the stop button, press the start button, and the machine begins to rotate.
- (3) The speed knob can adjust the grinding speed of the machine, clockwise rotation is for acceleration, and counterclockwise rotation is for deceleration. Low and medium speed is used in rough grinding, high speed is



forbidden to be used for rough grinding, and medium and high speed is used in fine grinding or polishing.

- (4) For emergency stops, first rotate the speed knob counterclockwise to zero speed, and then press the stop button.
- (5) Adjust the water valve to inject water.
- (6) The machine can be connected to the vacuum cleaner to ensure dust-free operation during dry grinding.
- (7) During the grinding process, the staff should pay attention to the wear and tear of the abrasive material so that the grinding discs do not touch the floor and cause damage to the grinding discs.
- (8) The ventilation hole of the motor should not be blocked when it is used. Please clean up when it is blocked. Please ensure the normal ventilation of the motor.
- (9) Operation of additional weight: The additional weight which is patented design can increase pressure or reduce pressure to the floor according to the working condition.
 - a) **Increase pressure:** move the additional weight forward on the machine head, loose the locking screw on the additional weight, move the additional weight along the lever to the required position, lock the locking screw.



- b) **Reduce pressure:** loose the locking screw on the lever, move the additional weight backward to the fix position, loose the locking screw on the additional weight, move the additional weight along the lever to the required position, lock the locking screw.



c) **Tilt up the additional weight:** before upward the machine head, lock the additional weight to the hole on the lever, move the additional weight to the tilted position, fix the locking screw to the positioning bolt on the wheel leg, be careful not to move too fast and too hard.



3.2 Equipment relocation after use

- (1) Place the hand shank in a suitable position and disconnect the power cable. Pull out the plug and put it in a dry place.
- (2) Uplift the machine head and clean the mud and dust from the bottom of the gearbox and the grinding plate system.



- (3) Clean the ventilation of inverter and motor. After the machine was used in a wet environment, pay attention to cleaning the surface of the machine.
- (4) Clean the dust of the inverter and the ventilation hole of the motor with a dry rag to avoid failure due to the backlog of dust in the next use.
- (5) Check whether the machine and its accessories are in good condition. Conduct necessary maintenance before storing it.
- (6) Store the machine in a clean, dry place. When storing, keep the handle in the vertical position and lock it tightly.

3.3 Handling of equipment

- (1) Before moving the machine, make sure that the industrial connector on the power supply cable has been pulled out of the machine and the water tank has no excess water.
- (2) When handling, it must be safe to use the lifts with a bearing capacity greater than the weight of the machine. Two people should cooperate in lifting, one person steps on the lift, and another person holds the handle, notices that the machine's grinding disc must be placed on the effective position of the lifter, and pays attention to the center of gravity should be stable, slow operation, and light handling to avoid colliding with other items and walls; If one person is unable to complete this operation, please assign multiple people to complete the operation.
- (3) You may use lifting rods when handling, be careful not to put your feet into the gearbox cover.

Chapter IV Equipment Connections and Reset of Inverters

4.1 Guide to Wiring

- (1) The power supply cable of this equipment shall use products that meet the relevant standards. The motor of 220V and 11KW recommends that the external cable use 6mm²X3 cable, and the motor of 380V and 11KW recommends that the external cable use 3 * 4mm² +1 * 2.5mm² or 4mm² X4 cable to ensure that the cable has sufficient load flow.
- (2) The wiring must be performed by a professional certified electrician.
- (3) The electrical system of this equipment must strictly follow the parameters (voltage, frequency) marked on the motor nameplate. Before connecting the power supply, please check and ensure that the voltage and frequency of the external power supply meet the requirements of the machine.

- (4) The grounding line of the equipment must be reliably connected to the ground line of the power supply system to prevent the operator from being subjected to electric shocks.
- (5) The power supply cable of this equipment shall use 3 wires and 1 grounding wire. Please insert the plug of the power supply cable into the suitable power socket. The grounding wire in the cable shall be connected to the grounding terminal in the industrial plug and industrial connector. It is strictly forbidden to connect the ground line to the ground line of the non-power supply system.

4.2 Switch boxes, inverter and electrical wiring

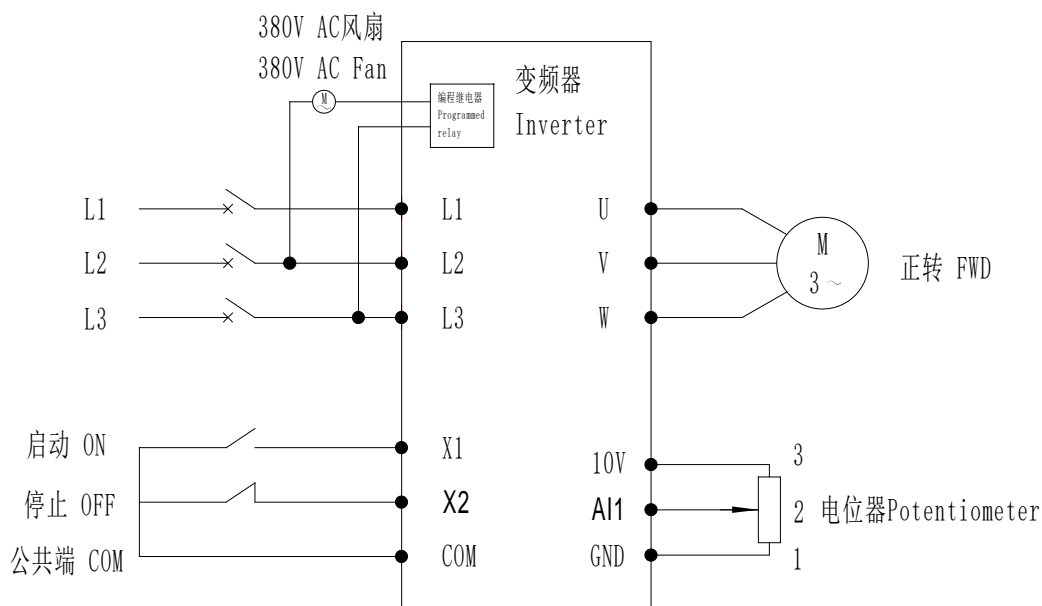

4.3 Reset of inverter

When the device is shut down due to low voltage or overload, turn off the power and turn it on after three minutes. The device can resume normal operation. If not, you can also use the control panel for reset. See the user manual of the inverter.

Chapter V Maintenance and Repair of Equipment

5.1 Maintenance and Repair

- (1) After the equipment being in use for 20 days, please clean up the dust of the ventilation filter, dust removal before operating. If the equipment is dry grinding without vacuum cleaner connection, it is necessary to clean up the dust of the ventilation filter once in 2 days.



- (2) When using this equipment for dry grinding, staff must be equipped with a suitable vacuum cleaner.
- (3) Please change gear oil of 220 # regularly. The new machine grinds about 10,000 square meters and needs to change gear oil once. After 12 months of grinding period, change gear oil once. The FNX800 needs 11 liters of gear oil of 220 #.
- (4) Please regularly add oil, after every 2 to 3 months, open the oil hole screw plug, check the oil level height, not less than 40mm, if it is less than 40mm, please add oil to the oil level height of 50mm.
- (5) Please clean the surface of the equipment after each use of the equipment and place it in a dry and cool place for the next use to increase the service life of the machine.
- (6) Please strictly comply with the requirements of the instruction manual to operate this equipment so as to avoid unnecessary loss of property.

Chapter VI Quality Assurance

6.1 Scope and duration of warranty

Since the date of purchase of this equipment, the warranty period of the motor is one year and frequency converter is 18 months as specified by the manufacturer, gearbox warranty period is one year, water supply switches, racks, handles, grinding disc and other vulnerable parts warranty period of three months.

6.2 Conditions of warranty

- (1) Under the promise of strict compliance with this manual, non-human's improper operation, warranty parts are damaged during the warranty period, and the manufacturer provides free repair and replacement.
- (2) If the customer needs to repair by himself, it must be done under the manufacturer's permission and in accordance with the guidance plan, Otherwise the manufacturer will not be legally liable.
- (3) If the equipment fails due to improper disassembly, we shall charge for maintenance.
- (4) Please keep this warranty card properly. Please attach it immediately after the warranty, otherwise it will not be handled.
- (5) If the vulnerable parts are judged to have been intentionally damaged during the warranty period, it is not within the scope of the warranty.
- (6) If the motor or inverter is burned or damaged is by an abnormal voltage during operation (for example, voltage range of FNX800 is 220V-240V, and the construction voltage in the United States is 440V-480V, which is an abnormal voltage for the equipment), it is not covered by the warranty.



- (7) When the machine cannot run normally due to the wrong wiring method, if it is necessary for the manufacturer to send people to overhaul, if the non-machine fault is checked by the maintenance people, the customer must pay the travel expenses and working fee within the warranty period.

Chapter VII Simple Fault Removal

If there is a sudden shutdown during the operation of the machine, please check it as follows:

- (1) Check whether the connection wire screw of the power supply general switch is secure and the ammeter number meets the machine requirements (50 amps or more is recommended).
- (2) Check whether the internal wiring of industrial plugs, industrial connectors, and sockets is loose or has poor contact.
- (3) Check whether the inside of the motor junction box is wet or burned.



Equipment warranty card for FNX800

After-sales service Site:			
Customer Name			
Contact person		Telephone	
Machine Type		Motor Model	
Converter model		Purchasing Date	
Fault Description			
Solution			
Remarks			
Customer's		Date	
Signature			
Repairman's		Date	
Signature			
Note:			
<p>1. The warranty period of motor of FNX800 is one year and frequency converter has a warranty of 18 months. The warranty period of gearbox is one year. Other vulnerable parts which includes water supply switches, racks, handles, grinding disc has a warranty period of three months</p> <p>2. Please do not refit or disassemble our equipment. If the equipment is refitted or disassembled, our company will not guarantee it.</p> <p>3. If there is any problem with the machine, you can consult Flooring Wholesale Ltd first.</p>			